

Installation instructions

for contractors

VIESMANN

Vitomax 300-LW

Type M82A

Oil/gas low pressure hot water boiler

Heating output 2.1 to 6.0 MW



VITOMAX 300-LW



Safety instructions



Please follow these safety instructions closely to prevent accidents and material losses.

Safety instructions explained



Danger

This symbol warns against the risk of injury.



Please note

This symbol warns against the risk of material losses and environmental pollution.

Note

Details identified by the word "Note" contain additional information.

Target group

These instructions are exclusively intended for qualified contractors.

- Work on gas installations must only be carried out by a registered gas fitter.
- Work on electrical equipment must only be carried out by a qualified electrician.
- Commissioning must be carried out in accordance with Viessmann regulations. We recommend the system is commissioned by Viessmann Industrieservice.

Regulations

Observe the following when working on this system:

- Statutory regulations regarding the prevention of accidents

- Statutory regulations regarding environmental protection
- Health and Safety at Work Act [Germany]
- The Code of Practice of relevant trade associations
- Directive 97/23/EC, as well as the relevant safety regulations of the following countries:

- Ⓓ DVGW, TRGI, TRF and VDE, TRD
- Ⓐ KG, ABV, LRG-K, LRV-K, DKBG
- ⒸⒽ SEV, SUVA, SVGW, SVTI, SWKI, VKF and EKAS guideline 1942: LPG, part 2

Working on the system

- Close the fuel shut-off valve and secure against unintentional reopening.
- Isolate the system from the power supply (e.g. by removing the separate fuse or by means of a mains isolator) and check that it is no longer 'live'.
- Safeguard the system against reconnection.

Index

Storage of Vitomax boilers prior to installation as part of the overall plant	4
Preparing for installation	5
Installation sequence	
Handling and installing the boiler.....	6
■ Recommended minimum clearances.....	6
Connecting the pipework.....	7
Fitting the measuring and control equipment.....	9
■ Preparing the control unit installation.....	9
■ Equipment for control and limitation.....	9
Connecting the flue gas side.....	9
■ Fitting a flue pipe.....	10
Mounting the sight glass.....	11
Fuels.....	11
Mounting the burner.....	12
Adjusting the burner.....	13
Commissioning and adjustment	14

Storage of Vitomax boilers prior to installation as part of the overall plant

Please note

*This information applies to boiler storage **prior to installation** as part of the plant and must be observed.*

- Vitomax boilers must be stored in enclosed rooms, free from weather influences under dry conditions.
- The room temperature must not fall below 0 °C or exceed +50 °C.
- In its delivered condition the boiler is protected against the ingress of foreign matter on the water side with dummy flanges or caps.
- Remove the shipping packaging to prevent the formation of condensate.

To prevent corrosion in the non-pressurised state, observe the following if the boiler is stored for > 4 weeks:

- Protect the interior of the boiler against moisture on the flue gas side and on the DHW side with a desiccant, e.g. silica gel.
- The amount of desiccant depends on the boiler volume.
- Check the effectiveness of the desiccant regularly.

Note

Observe the desiccant manufacturer's instructions.

- Ensure that the desiccant does not come into contact with the boiler material (e.g. by suspended fixings).
- Preserve the dry flue gas side with a thin film of graphite or boiled oil.
- Instead of the moisture extraction on the flue gas side by means of a desiccant, a dryer with air circulation can also be connected.

Preparing for installation

Note

All diagrams in this document are schematic diagrams.

Handling the boiler



Danger

Inappropriate handling of the boiler can result in serious health risks for the personnel engaged in the handling.

Observe all relevant accident prevention regulations.

Only use the marked fixing points.

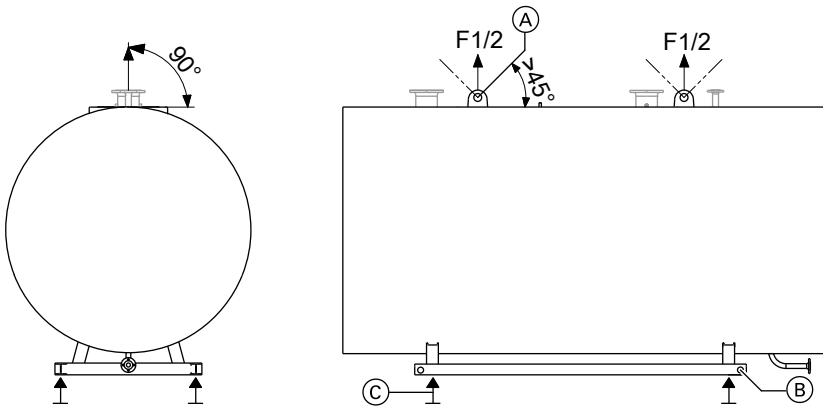

Fig. 1

1. Lifting the boiler

Use lifting eyes (A) (\varnothing 80 mm) or lifting points (C) on the boiler base.

2. Moving the boiler

- Place steel rollers underneath base rail (C).
- Secure the pulling equipment to tie-down points (B) (\varnothing 80 mm).

Handling and installing the boiler

Recommended minimum clearances

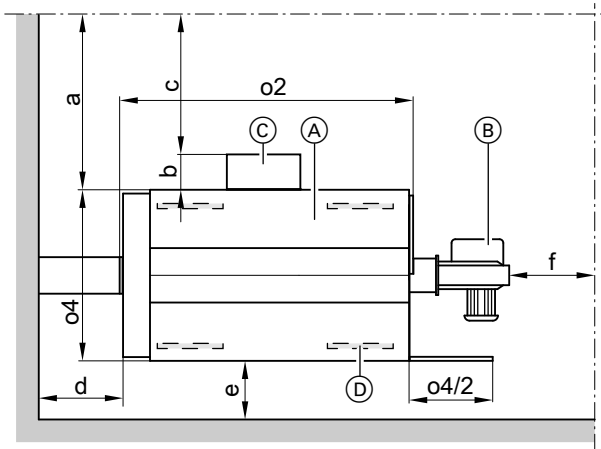

Fig. 2

- | | | | |
|-----|---|--------|--------------------------|
| (A) | Boiler | a | Control panel not fitted |
| (B) | Burner | b | Control panel depth |
| (C) | Regulating and control system | c | Control panel fitted |
| (D) | Anti-vibration boiler supports (option) | d,e,f | Remaining clearances |
| | | o2, o4 | Max. length, max. width |

Tab. 1

a/b/c	mm	≥1000/≥500/≥800
d/e/f ¹	mm	≥500/≥300/≥500

Observe the given dimensions to **ensure easy installation and maintenance**.

Level the boiler horizontally. **Observe risk warning** in chapter "Handling the boiler".

We recommend

you position the boiler onto anti-vibration boiler supports. For this, distribute supports evenly over the length and centrally underneath the base rails. Observe the information provided.

Tab. 2

Boiler size		1	2	3	4	5	6	7
o2	mm	3970	4200	4460	4720	5070	5420	5780
o4	mm	2025	2100	2200	2325	2410	2485	2575

¹ **We recommend:** Leave one boiler length (o2) of space clear in front of the boiler door to facilitate the extraction of turbulators (if fitted) and cleaning.

Connecting the pipework



Danger

Opening the boiler connections on the water and steam side whilst the boiler is under pressure can lead to a high risk of severe injury.

Only open the connections on the water and steam side after the boiler has been completely depressurised.



Please note

Unsuitable water quality can damage the boiler shell.

Only fill the boiler with water that complies with the "Water quality guidelines" (see service instructions).

Note

Install all pipe connections free of load and torque stress.

1. Thoroughly flush the system (especially when connecting the boiler to an existing system).
2. Make all necessary connections.

Connecting the pipework (cont.)

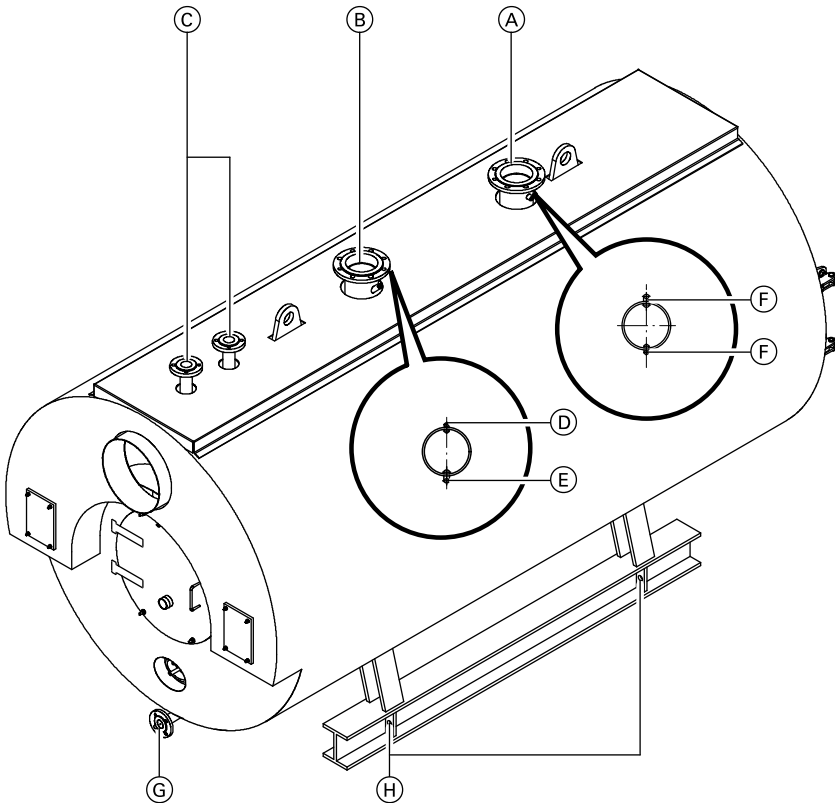

Fig. 3 - Illustrative example. Order-specific deviations from the standard delivery are possible.

- | | | |
|---|--|---------|
| (A) Boiler return connector | (F) Fem. connection for additional control equipment | R ½ |
| (B) Boiler flow connector | (G) Drain connector | |
| (C) Safety valve connector | (H) Drilled hole for equipotential bonding | Ø 13 mm |
| (D) Fem. connection for high limit safety cut-out | | R ½ |
| (E) Fem. connection for temperature controller | | R ½ |

Fitting the measuring and control equipment

Fit measuring and control equipment that is pressure tested to the same level as the operating pressure of the boiler and that is suitable for the intended operating mode (operation with or without constant supervision). Agree details with the responsible approval body, which should also approve them.

Note

Carry out the installation in accordance with the instructions supplied with the equipment.



Power supply

Connection and wiring diagrams supplied

Preparing the control unit installation

Vitotronic or **Vitocontrol** as an accessory:



Separate documentation

Equipment for control and limitation

For boilers with a **Vitotronic** control unit or **Vitocontrol** control panel:



Separate documentation

Connecting the flue gas side



Danger

The gases created inside the boiler may be poisonous and can result in severe health risks if they are allowed to escape unchecked.

Close unused boiler apertures tightly and check gas lines for tightness.

Connecting the flue gas side (cont.)

Fitting a flue pipe

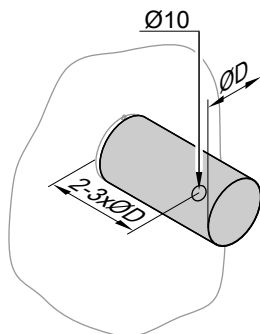

2. Locate the test port (approx. 10 mm Ø) at a distance of two to three times the diameter of the flue pipe downstream of the flue outlet.
3. Seal flue pipe.
4. Insulate the flue pipe.

Optional

Flue gas flange with mating flange.

Fig. 4

1. Connect the flue outlet with the flue system using a flue pipe with favourable flow characteristics.

Tab. 3 - Flue outlet $D^{\wedge 2}$

Boiler size	1	2	3	4	5	6	7
D	$\text{Ø}346$	$\text{Ø}392$	$\text{Ø}392$	$\text{Ø}440$	$\text{Ø}490$	$\text{Ø}550$	$\text{Ø}620$

Note

- Prevent the return of condensate created inside the flue system by suitable on-site measures (condensate trap).
- Close the condensate drain connectors if they are not used. They are designed to drain any condensate collected in the start-up phase.

Note

Connect all flue pipes free of load and torque stress. Flue pipe joints must be gas-tight.

^{\wedge 2} Internal diameter, for external diameter for size 1 to 3: + 8 mm, for size 4 to 7: + 10 mm

Mounting the sight glass

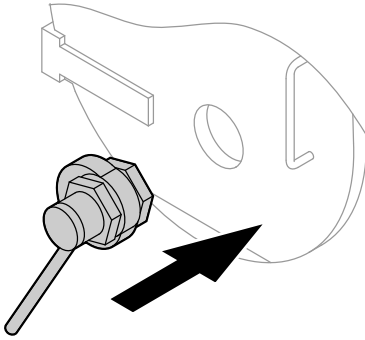

Fig. 5

Mount the sight glass (supplied with the flame tube) into the cleaning aperture closure at the back of the boiler.

Fuels

Oil

- Fuel oil EL to DIN 51603, part 1.
- Fuel oil S or SA to DIN 51603 part 3, 5. When using fuel oil S or SA, different output data (heating output, flue gas temperature, efficiency) may result.

Gas

- Natural gas and LPG in accordance with DVGW Code of Practice G 260/I and II or in accordance with local regulations.

Alternative fuel

- On request

Mounting the burner

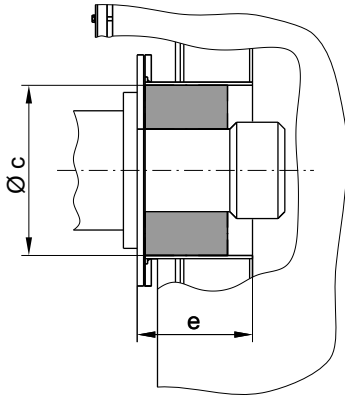

Fig. 6

- c Max. flame head diameter
- e Minimum flame head length (table 4)



Separate burner instructions, connection and wiring schemes as well as operating and service instructions.

1. For the burner connection, secure the burner plate to the boiler flange with screws.

Note

If the burner plate was not pre-drilled at the factory, drill the burner fixing holes into the burner plate and cut out the flame head aperture.

2. Secure the burner to the burner plate with screws.

Note

For different dimensions, adjust the cut-out in the thermal insulation according to the flame head diameter.

3. After mounting the burner, seal the annular gap between the flame head and the thermal insulation block with heat-resistant insulation material.

Note

Thermal insulation blocks and loose thermal insulation are supplied either inside the reversing chambers of the boiler doors or inside the flame tube.

4. Close the boiler doors and cleaning aperture at the back of the boiler.

Note

Check for gas tightness.

Adjusting the burner

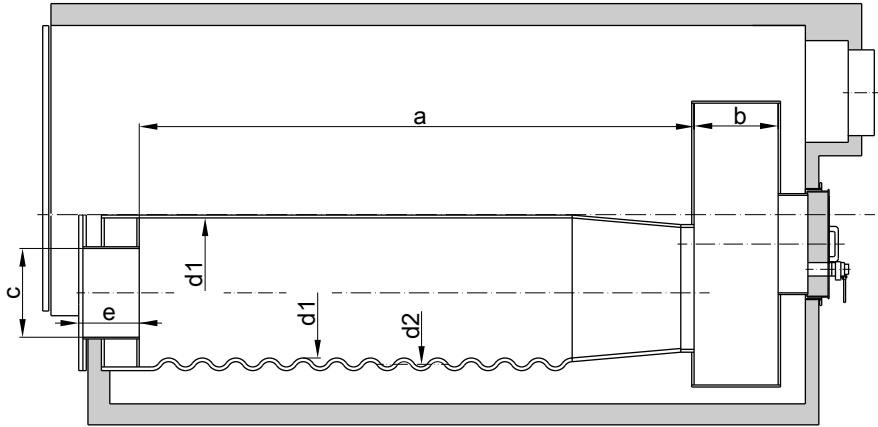

Fig. 7

- a Flame tube length
- b Reversing chamber depth
- c Max. flame head diameter
- d1 Smooth pipe, internal diameter, min.
- d1 Corrugated pipe, internal diameter
- d2 Corrugated pipe, average diameter
- e Minimum flame head length

Tab. 4 - Burner connection dimensions

Boiler size		1	2	3	4	5	6	7
c	Ømm	520	520	590	590	590	718	718
e	mm	360						

Note

The type of flame tube depends on the pressure stage employed. Product-specific tolerances are possible.



Separate burner documentation.

Note

Adjust the highest oil or gas throughput of the burner to the specified maximum combustion heating output of the boiler.

Commissioning and adjustment



Service instructions of the boiler
and separate documentation.

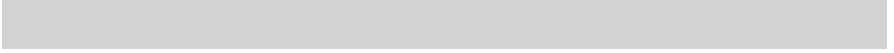

Viessmann Werke GmbH&Co KG
D-35107 Allendorf
Telephone: +49 6452 70-0
Fax: +49 6452 70-2780
www.viessmann.com

Viessmann Limited
Hortonwood 30, Telford
Shropshire, TF1 7YP, GB
Telephone: +44 1952 675000
Fax: +44 1952 675040
E-mail: info-uk@viessmann.com

5774 495 GB Subject to technical modifications.